

Model 800-L Big & Tall Leather Chair

Parts Listing

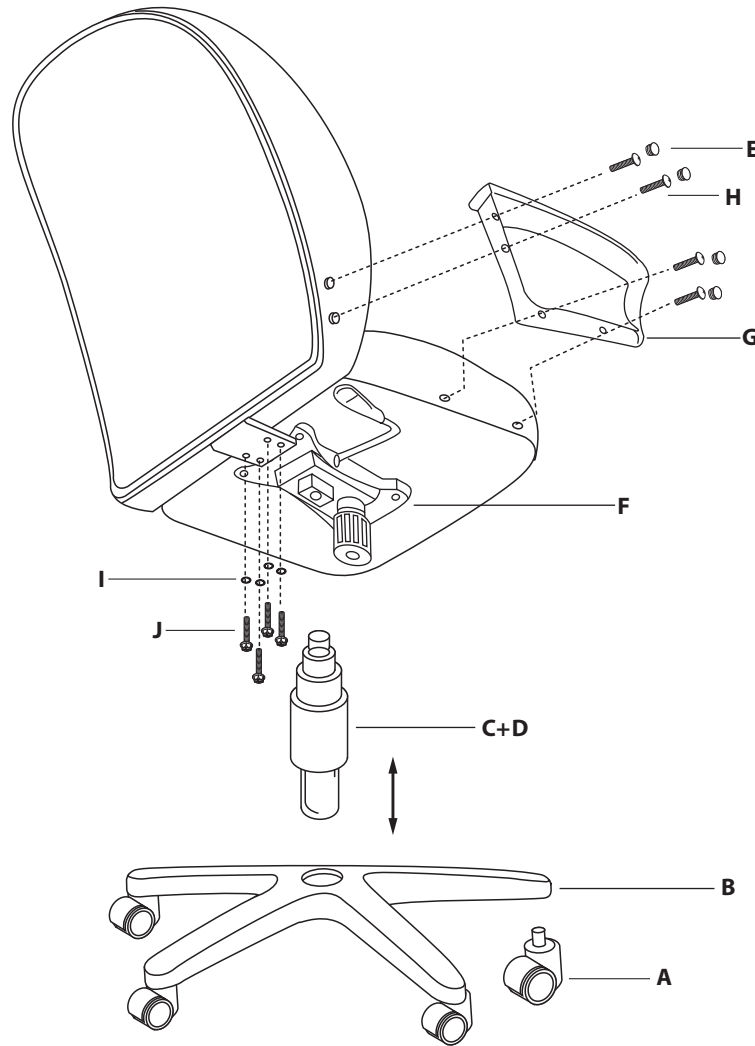
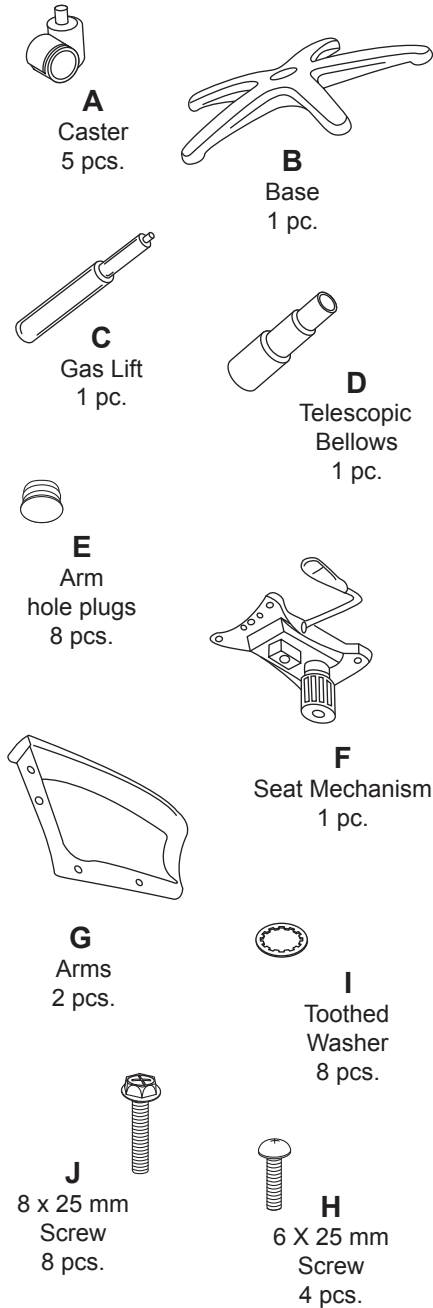

Assembly Instructions

Tools Needed: Phillips Head Screwdriver

Please read all instructions before assembly.

- Step 1:** Insert Casters (A) into Base (B).
- Step 2:** Insert Gas Lift (C) into Base (B).
- Step 3:** Cover Gas Lift (C) with 3 piece Telescopic Bellows (D).
- Step 4:** Place Chair Seat on a level, non-abrasive surface and align pre-drilled holes in Seat Mechanism (F), with holes in Chair Seat.
- Step 5:** Place four 8 x 25 mm Screws (J) and washers (I), insert through the holes in the Seat Mechanism (F), and into the Chair Seat. Tighten with screwdriver.
- Step 6:** Attach Seat Back, under Chair Seat, (end with pre-drilled hole) using 8 x 25 mm screws (J) and washers (I). Tighten firmly.
- Step 7:** Attach fixed arms (G) using 4 screws (H) for each side attaching to drilled holes on sides of seat and back. Tighten firmly and insert plugs to conceal screws.
- Step 8:** Carefully place Chair Seat (E) with attached Seat Mechanism (F) onto the Gas Lift (C), aligning the hole in the Seat Mechanism with the Gas Lift.
- Step 9:** Carefully sit on chair to make sure the Gas Lift (C) is properly inserted into the Base (B).
- Step 10:** Operate the Gas Lift Lever and the Back Posture Adjustment Lever on the Seat Mechanism (F), to be sure unit is working properly.

CAUTION:

1. Do not use this chair as a step ladder.
2. Check for loose screws and tighten them every 6 months.



Holly Springs, NC, USA
 800-520-7471 (voice)
 919- 303-6389 (voice)
 919-362-4765 (fax)
 support@ofminc.com
 www.ofminc.com