



Rapid-Cam™
Adjustment System



Anti-Flex Anchor Plate

- 60"x38" Backboard
 - Regulation Target
 - 3/8" Thick Acrylic
 - Foam Frame Pad
- Heavy-Duty Spring-Flex Rim
- 36" Offset from the Pole to the Backboard
- Rapid-Cam™ Height Adjustment Mechanism
 - Precision Height Indicator
 - Key Lock
 - Instant Adjustment from 7.5 to 10 Feet
- 5"x5" Steel Pole
 - 3/16" Wall Thickness
- Anti-Flex Anchoring System
 - Patented Anti-Flex design reduces pole vibration
 - Slotted for easy installation and removal



MAMMOTH®

BASKETBALL EQUIPMENT

9 8 8 6 0

- Mammoth's 60"x38" backboard has arena-style appearance and play. A steel frame supports the 3/8"-thick acrylic providing superior rebound. The steel frame is powder-coated with a rust-resistant finish. The professional-quality frame pad secures directly to the backboard.
- Mammoth's heavy-duty Spring-Flex Rim is built to take the abuse of competitive play. This breakaway-style rim features a wraparound brace supporting a 5/8" ring of solid steel. Includes all-weather nylon net.
- Engineered for stability, Mammoth's extension arms span 36 inches from the front of the pole to the backboard. This offset creates valuable playing area beneath the rim.
- One of the most exciting developments in home basketball is the ability to adjust the height of the goal to match the skill level of the player. The Rapid-Cam™ Adjustment Mechanism allows players of any age or size to adjust the backboard instantly, with little effort. The cams and counter-balance springs do the work for you, no crank required. The goal height is adjustable from 7.5 to 10 feet with infinite increments. The height indicator offers precision accuracy to the half inch. A key lock is included, giving owners the ability to prevent unwanted adjustment.
- Air shocks absorb the impact of aggressive play and dampen vibration.
- Mammoth's 5-inch square steel pole has a 1/8" wall thickness and a rust-resistant powder-coated finish.
- The Anti-Flex Anchoring System has a unique bolt-down design, with a standard 9"x9" hole pattern that allows for installation and removal of the system. It reduces pole vibration, minimizes intrusion into the playing area and is slotted for easy assembly.

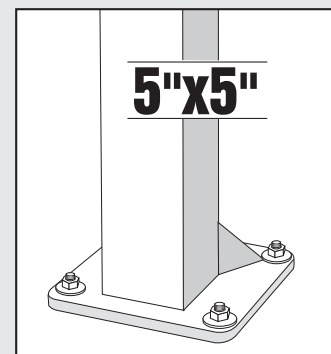
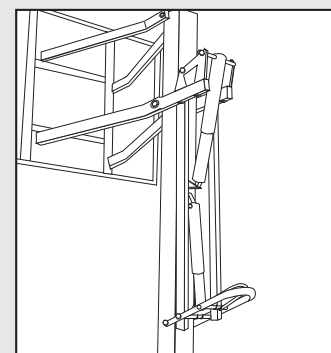
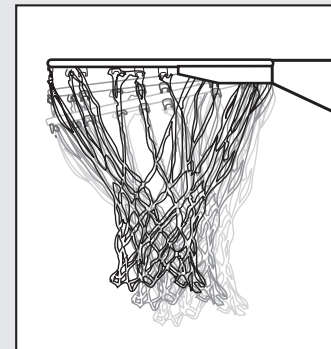

©2004 Lifetime Products, Inc.
 PO Box 160010
 Freeport Center, Bldg. D-11
 Clearfield, UT 84016-0010
 800-242-3865
 801-728-1907
 www.lifetime.com

BOX	WEIGHT	LENGTH	WIDTH	HEIGHT	Ft ³	UPS	UPC
Pole	215 lb	123"	12"	12"	10.25'	NO	0-81483-98860-3
Backboard	89 lb	62"	41"	7"	9.71'	NO	0-81483-98860-3
Rim	26 lb	26"	20"	8"	2.38'	YES	0-81483-98860-3